

ONE YEAR LIMITED WARRANTY

SpectraPure, Inc. warrants each new LiterMeter Precision Dosing System to the original owner only to be free of defects in material and workmanship for a period of 1 year from the date of receipt. SpectraPure's liability under this warranty shall be limited to repairing or replacing on SpectraPure's option, without charge, F.O.B. SpectraPure's factory, any product of SpectraPure's manufacture. SpectraPure will not be liable for any cost of removal, installation, transportation, or any other charges which may arise in connection with a warranty claim. Products which are sold but not manufactured by SpectraPure are subject to warranty provided by the manufacturer of said products and not by SpectraPure's warranty. SpectraPure will not be liable for damage or wear to products caused by abnormal operating conditions, accident, abuse, misuse, unauthorized alteration, or repair, or if the product was not installed in accordance with SpectraPure's printed installation and operating conditions or damage caused by power failures, freezing, flood, fire, or acts of God.

TERMS AND CONDITIONS OF SALE

To obtain service under this warranty, the defective system or components must be returned to SpectraPure with proof of purchase, installation date and failure date.

Any defective product to be returned to the factory must be sent freight prepaid; documentation supporting the warranty claim and/or a Return Goods Authorization must be included, if so instructed.

SpectraPure will not be liable for any incidental or consequential damages, losses, or expenses arising from installation, use, or any other causes. There are no expressed or implied warranties, including merchantability or fitness for a particular purpose, which extend beyond those warranties described or referred to above.

Some jurisdictions do not allow the exclusion or limitation of incidental or consequential damages and some jurisdictions do not allow limitations on how long implied warranties may last. Therefore, the above limitations or exclusions may not apply to you. This warranty gives you specific legal rights and you may also have other rights which vary jurisdiction to jurisdiction. SpectraPure, Inc. reserves the right to change prices without notice when necessary.

SpectraPure® Inc. assumes no responsibility for water damage due to leaks or misapplications of our products. It is the user's responsibility to determine that the system is leak-free and properly installed.

SpectraPure®

The LiterMeter III

Precision Dosing System

Installation and Operating Manual



System Description	3
System Specifications	3
System Features	4
Other Applications	4
Controls and Components	5
System Setup	6
Calibrating	7
Programming	8
Over Limit	8
System Operation	9
The Lights	10
The Buttons	10
The Information Display	10
Navigation Aids	11-12
Maintenance	13
Accessories	14-15
Two-Way Water Exchange	16
Dosing Multi-Part Additives	17
Hydroponics System Example	18
Connecting Other Devices	18
Notes	19
Troubleshooting	20
Servicing	21-23
Accessories and Replacement Parts	23

Copyright © 2002 by SpectraPure® Inc.
ALL RIGHTS RESERVED

No part of this publication may be reproduced, stored in a retrieval system, or transmitted in any form or by any means, electronic, mechanical, photocopying, recording or otherwise without the prior written permission of SpectraPure Inc.

of the pump body. Be sure that the tubing is completely pushed down into the ports. See Fig. B-3.

- 11: Place two of the three rollers into the pump body, pushing them against the tubing. Hold them in position with your left thumb and push the third roller into place. See Fig. B-4.
- 12: Replace the Teflon ring over and around the three rollers. You may have to push the third roller inward to position the ring properly. See Fig. B-5.
- 13: Carefully align the pump body with the lid and press together. See Fig. B-6. Make sure the two release tabs (referred to in Step 4) click and lock in place. Press the pump head assembly onto the motor shaft and click in place.
- 14: Reinstall the supply and delivery hoses. Use new cable ties to secure the tubing.
- 15: Before you re-calibrate your LiterMeter, a short break-in period is needed to insure an accurate calibration. Run it dry for one hour. Next, follow the calibration procedure outlined earlier in this manual.

ACCESSORIES & REPLACEMENT PARTS:

	Catalog No.	Optional Part	Price
	LM3-RPM	Remote Pump Module	\$ 119
	LM3-WXM	Water eXchange Module	\$ 149
	LM3-MPM	Micro Pump Module	\$ 119
	LM3-TCM	Topoff Control Module	\$ 39
	LM3-TRK	Tubing Replacement Kit	\$ 15
	LM3-MTRK	Micro Tubing Replacement Kit	\$ 12

Fig. B: Pump Head Maintenance

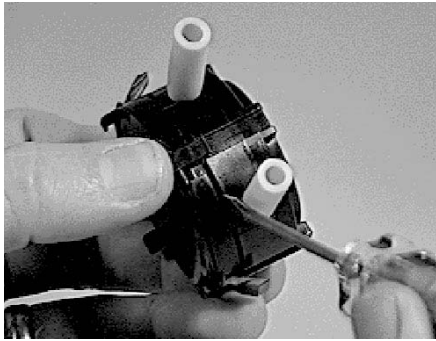

Fig. B-1

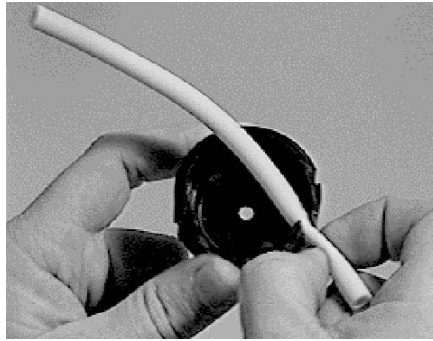

Fig. B-2

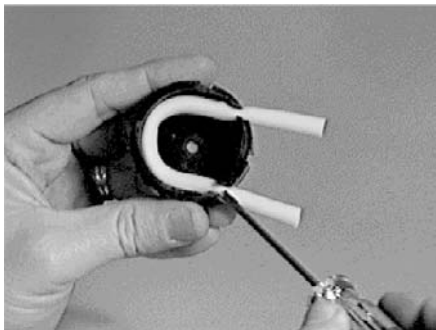

Fig. B-3



Fig. B-4

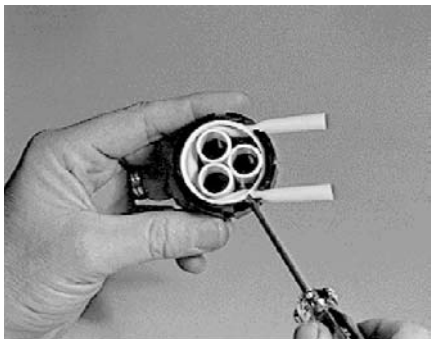

Fig. B-5

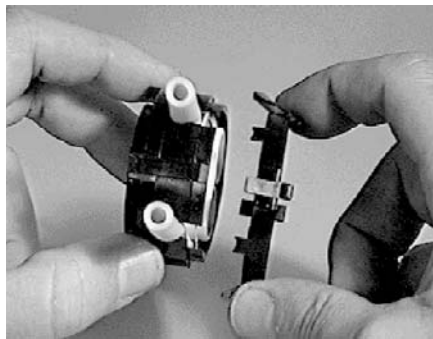

Fig. B-6

SYSTEM DESCRIPTION:

The LiterMeter III is a precision liquid dosing system with independent control of three peristaltic pumps, one is internal and two more can be remotely connected. The pumps may be of different sizes and flow rates.

The LiterMeter III offers features found only on expensive laboratory pumps, such as microprocessor control and non-volatile memory. Unlike noisy industrial metering pumps sold to the aquarium trades, the LiterMeter III was specially designed for critical aquarium dosing and is so quiet you can use it in your living room. Superior three-roller direct-motor drive eliminates noisy gears and improves flow accuracy and tubing life. It can be run dry without damage.

Calcium maintenance and alkalinity control are essential for a healthy reef tank. The LiterMeter III eliminates the manual drudgery of dosing Kalkwasser or trace elements, and topping off evaporated water. Kalkwasser replenishment, to be most effective, should be added to your aquarium slowly and consistently to avoid precipitation of calcium carbonate. The LiterMeter III automatically and reliably performs this task for you.

Other dosing and mixing operations involving 2- and 3-part formulae can be precisely metered and monitored. Two-way water exchanges can be performed automatically.

SYSTEM SPECIFICATIONS:

- **Internal Pump Flow Rate:** approx. 250 ml/min. (8.45 oz./min.)
- **Dimensions:** 7.5" x 3.7" x 2.2" (19 cm. x 9.4 cm. x 5.6 cm.)
- **Minimum Daily Total (per Pump):** 50 milliliters (1.7 oz.)
- **Maximum Daily Total (per Pump):** 99 liters (26 gals.)
- **Draw Height:** no more than 10 feet (3 meters)
- **Delivery Height:** no more than 16 feet (4.9 meters)
- Each pump doses equal amounts 150 times per day
- 115VAC / 12VDC wall-mounted power supply
- International power supply available: 230VAC
- Uses less than 6 Watts of power when operating one pump
- Can be powered directly from a 12VDC battery

SYSTEM FEATURES

- High quality and accuracy at a modest price
- Fully automatic operation - Set it and forget it
- Auto-Calibration feature
- Virtually maintenance free
- No check valves to clog or seals to leak
- Self-priming and anti-siphoning
- Compact size and cool operation
- Kalkwasser safe
- No damage to the unit if run dry
- Quiet operation and low power consumption
- Complete system consumes less than 6 W.

OTHER APPLICATIONS

- Automatic Invertebrate Feeding
- Hydroponics Nutrient Dosing and Mixing
- Bio-Remediation
- Methanol Dosing for Bio-Reactors and De-Nitrifiers
- 2-part calcium additives, such as B-Ionic and C-Balance products,
- Laboratory use

SERVICING THE LiterMeter III

It is recommended that pump heads be inspected and cleaned per the following procedure.

- 1: Remove the pump head by gently depressing the two opposing release clips and lifting the pump head from the motor shaft.
- 2: Clip the cable ties, being careful not to cut the pump tubing.
- 3: Disconnect the supply and delivery hoses from the pump tubing, taking care not to splash or spill any liquid in the tubing.
- 4: Gently depress the release tab (located between the inlet and outlet tubing ports) with your left thumb and insert a small flat screwdriver into the gap between the pump lid and body. Rotate the screwdriver 90 degrees to separate the lid from the body. Repeat on the opposite side. See Fig. B-1.
- 5: Pull the two halves apart and set the lid and Teflon® ring aside.
- 6: Remove the three white rollers and tubing from the body.
- 7: Clean the three white rollers, tubing, lid and body with a cloth soaked in De-Solv-it® (available in most grocery stores), acetone, or petroleum spirits. Make sure you remove **all** gummy deposits then rinse parts with water and dry. Next, wipe the motor shaft clean. If you use acetone, be careful not to spill on the plastic case or it will damage the finish. Keep cleaning fluids away from the bearing at the base of the shaft.
- 8: Inspect the tubing for cracks and/or excessive wear. Replace when necessary.
- 9: Reverse or flip the tubing end-to-end and reinstall by pinching it one inch from an end and inserting it into the outlet port of the pump body. Position the tubing so that an un-worn side will be against the rollers. See Fig. B-2.
- 10: Pinch the other end of the tubing and insert it into the inlet port of the pump body. Manipulate the tubing so that it conforms to the inside diameter of the pump body and is resting on the bottom step

TROUBLESHOOTING

Symptom	Remedy
Noise	The LiterMeter III is considered the quietest pump on the market, but the pump will produce some noise. Here are some suggestions to limit any perceived noise. 1. Do not attach the LiterMeter to a box or enclosure that will act as a "speaker" and amplify the vibration of the pump. 2. Keep the attached tubing from vibrating against nearby walls, cabinets or other objects. 3. If the LiterMeter develops a "grinding" noise, follow the cleaning procedures
Lights and Display are on, but rollers are not turning	Determine if drive shaft is rotating. If not: Call Technical Support. If shaft is turning: The pump head needs to be cleaned. See next page.
After cleaning, the shaft spins but the rollers are not turning	1. Cleaning was not properly done - Re-clean. 2. Roller may be cracked - Inspect. 3. Teflon ring is missing - Replace. 4. Oil residue in driveshaft - Remove oil. 5. Tubing not properly installed - Adjust. 6. Pump head not properly attached.
Pump is running but no fluid is being pumped	1. Check the ends of the tubing. Kalkwasser or other-substances may be blocking the lines at either tubing end. 2. Loose connection on the Suction side will cause it to lose its prime.
Pump is running but flow rate has diminished	1. Pump requires cleaning - Clean and Reset 2. Partially lost prime - check for air leaks.

CONTROLS AND COMPONENTS

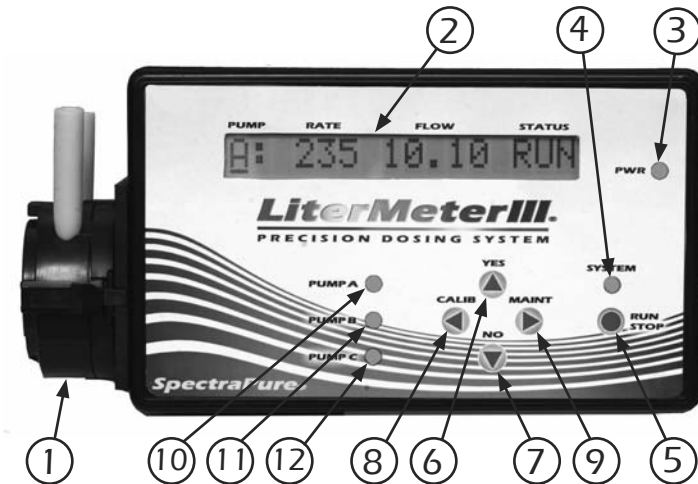

LiterMeter III Controls and Components

- | | |
|-------------------------------|--------------------------|
| 1. Pump Head | 10. Pump "A" Indicator |
| 2. Information Display | 11. Pump "B" Indicator |
| 3. Power Indicator | 12. Pump "C" Indicator |
| 4. System Operation Indicator | |
| 5. RUN/STOP Button | 13. Power Input Jack |
| 6. UP Button (YES) | 14. Pump "A" Output Jack |
| 7. DOWN Button (NO) | 15. Pump "B" Output Jack |
| 8. LEFT Button (CALIBrate) | 16. Pump "C" Output Jack |
| 9. RIGHT Button (MAINTenance) | |

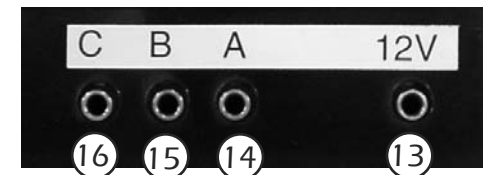

LiterMeter III Side View

SYSTEM SET-UP

1. To assure secure connections, it is recommended that the ends of the ¼" polyethylene tubing be heat-formed into "barbs" by briefly melting the ends with an open flame, until the tubing melts into the shape shown in the illustration below.

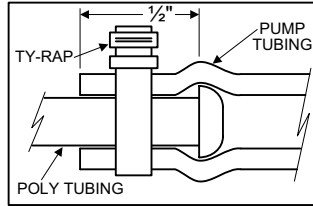
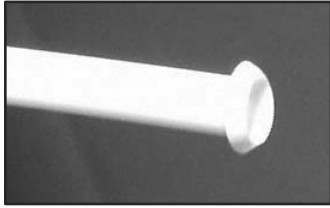

2. Press-fit the barbed-end of a piece of ¼" polyethylene tubing into the rubber **outlet** hose (arrow pointing away from the pump) at least ½". Secure with one of the provided cable ties. This should lead to your aquarium (or sump).
3. Press-fit the barbed-end of another piece of ¼" polyethylene tubing into the rubber **inlet** hose (arrow pointing toward the pump) at least ½". Secure with a provided cable tie. This is connected to the supply reservoir. This reservoir needs to be vented to prevent occlusion.
4. Although the peristaltic pump inherently prevents back-flow conditions, it is always good practice to locate the LiterMeter above and to the side of the supply vessel and aquarium (or sump). Providing an air-gap between the hose end and the top-most water level in the aquarium is also accepted practice. Note: when metering Kalkwasser, the end of the tubing will eventually become calcified and interfere with the flow. To prevent this, it is suggested that the end of the dispensing tubing be inspected and cleaned periodically.
5. The supply reservoir can be any size and located as much as 10 feet below the LiterMeter. If the LiterMeter is located at the same level as the supply tank, delivery to a height of 16 feet above the LiterMeter is possible.
6. Connect the 12 VDC, 500 mA power supply to the power jack (13) on the side of the LiterMeter III, and then to any proper 120 VAC source (230 VAC power supply available).

NOTE: Do not connect the power supply to the pump output jacks. The power supply may be damaged and your warranty may be voided.

NOTES:

HYDROPONICS SYSTEM EXAMPLE

An example using the LiterMeter III for the hydroponics industry is shown below. Nutrient components "A" and "B" are metered and mixed in precise amounts into the hydroponics reservoir. At the same time, an amount equal to "A" plus "B" is removed from the reservoir by Pump C. Small but constant replenishments of the nutrient is conducive to proper plant growth. The optional Top-off Control Module will shut the entire system down if the reservoir level becomes too high.

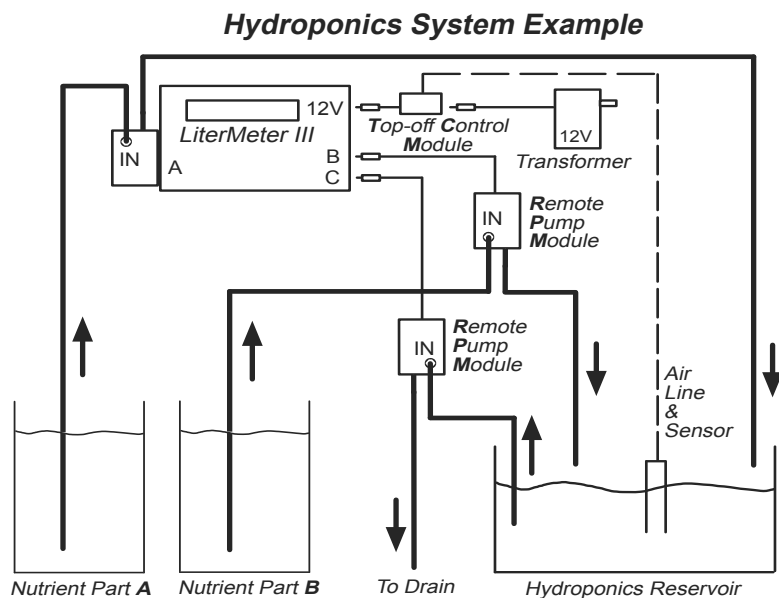

CONTROLLING OTHER DEVICES

Connecting an external device to the "A" output jack will disable the internal pump. All three outputs can control many different devices for various applications. **Interface specifications are 12 Volts, DC at no more than 500 milliamps.** This is adequate to power many types of solenoids, relays and pumps. The connector is a 1/8" (3.5mm) male plug, center pin is positive.

CALIBRATING THE LiterMeter III:

All peristaltic pumps exhibit a "breaking-in" period where the tubing needs to become "seated" in the pump head. Variations in pumping height and liquid viscosity will also affect the flow RATE of the pump. Over time, these pumps may slightly change their flow RATE characteristics and need to be re-calibrated periodically. Always run a new (or serviced) pump dry for an hour before calibrating.

ALL PUMPS OFF

(CALIB)

A: START CALIB? ^

(YES)

A: 500mL FULL? ^

(YES)

B: START CALIB? ^

(YES)

B: 500mL FULL? ^

(YES)

C: START CALIB? ^

(YES)

C: 500mL FULL? ^

(YES)

ALL PUMPS OFF

The LiterMeter III needs to know each pump's flow RATE. This procedure will automatically determine the actual flow RATE of the pump(s):

- 1: When *ALL PUMPS OFF* is displayed, place the intake hose of Pump A into the vessel (larger than 500 mL) of liquid to be calibrated. Place the output hose into a 500 mL measuring cup.
- 2: Press the RUN/STOP button and then turn ON the pump to be calibrated long enough to be sure that the pump is "primed" and ready to dispense the liquid. Press the RUN/STOP button to return to *ALL PUMPS OFF*. Empty the measuring cup.
- 3: Enter Calibrate Mode by pressing the CALIB button (LEFT).
- 4: Press the YES button (UP) to begin to fill the measuring cup.
- 5: When the cup has filled to the 500 mL mark, press the YES button (UP) again.
- 6: The pump will shut off and the RATE of the pump will be calculated and displayed in mL/min. for a short time before continuing on to the Pump B calibration.
- 7: If there are no more pumps to calibrate, press the NO button (DOWN) to cancel subsequent calibrations and return to the *ALL PUMPS OFF* display.

PROGRAMMING

One of the most common uses of the LiterMeter III is to dispense a metered amount of kalkwasser on a daily basis from a reservoir containing many days' worth.

- 1: Review the Navigation Aids on pages 11-12 to familiarize yourself with using the buttons.
- 2: CALIBrate the individual pump (See page 7).
- 3: Set the FLOW value for the **amount in liters** you wish to dispense **each day**.

Example: If your goal was to add 4 and 1/2 Liters of Kalkwasser to your aquarium every day, you would set the daily total FLOW value to read **04.50**.

Example: if your goal was to add two gallons of Kalkwasser to your aquarium per day, you would set the daily total FLOW value to read **07.56** (1 U.S. Gallon = 3.78 Liters x 2 = 7.56 Liters).

- 4: Change the STATUS from OFF to RUN and the pump will operate just long enough, 150 times a day to deliver the daily total FLOW. Changing the STATUS from OFF to ON will cause the pump to operate continuously until the STATUS is changed to OFF.

Power outages will not affect the LiterMeter III. If power is removed from the unit, and then re-applied, timing and control will commence with the same settings as before the power outage.

OVER LIMIT

If the requested daily total (FLOW) is more than the pump's capacity, the display will indicate the STATUS as OVL, or an Over Limit condition. In this case, the pump will be turned off and the daily total (FLOW) will be adjusted to indicate the maximum FLOW attainable with that pump. Change the STATUS to OFF and either adjust the requested FLOW to a more suitable value, or change the STATUS back to RUN to use the adjusted maximum FLOW.

DOSING MULTI-PART ADDITIVES

Many different brands of 2- and 3-part additives are available today. For example, using the B-Ionic and C-Balance products, the LiterMeter III enables you to automate the daily additions of both components.

In the example below, Pump A dispenses "Additive Part A". Pump B is a Remote Pump Module and dispenses "Additive Part B". A micro-nutrient or "Additive Part C" is dispensed by another Remote Pump Module. The optional Top-off Control Module will shut the entire system down if the sump level were to ever become too high.

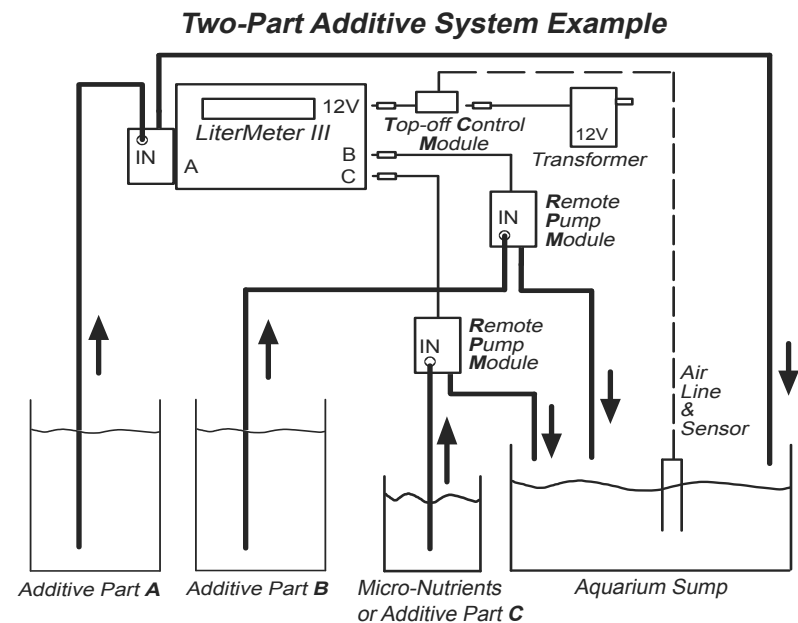

TWO-WAY WATER EXCHANGE

Two-way water changes have been a problem in the past. Two pump heads mounted on one shaft can have different flow RATES and thus unequal totals after a period of time. The LiterMeter III solves this problem by providing individual pump flow RATE calibrations. With two pumps properly calibrated, a constant water exchange system can be set up.

In the example below, Pump A dispenses nutrients or kalkwasser. Pump B is the Water eXchange Module. It takes water from a pre-prepared reservoir of fresh salt water and meters it into the aquarium. Pump C is a Remote Pump Module that takes an equal amount of water from the aquarium and sends it to the drain. The air line & sensor attached to the Water eXchange Module will insure against over-filling the sump due to a system failure.

Aquarium System Example

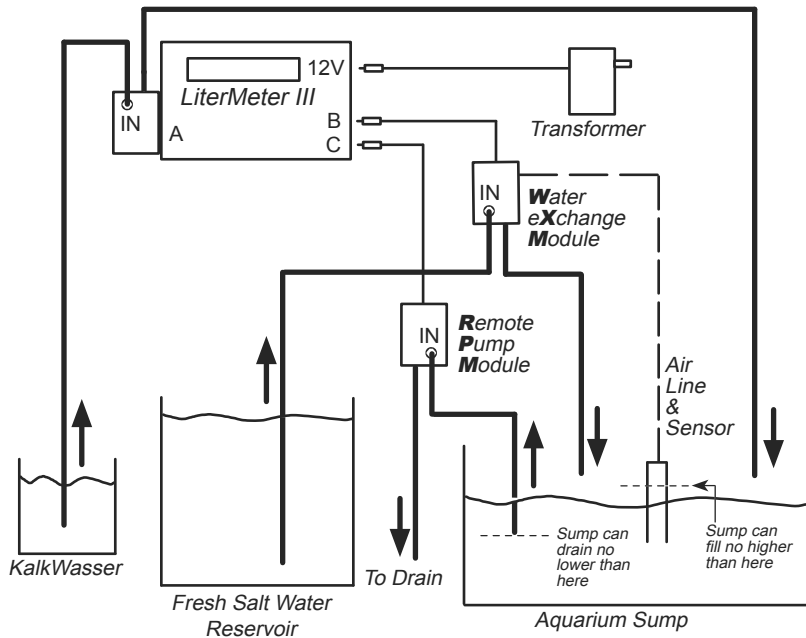

Typical System Example

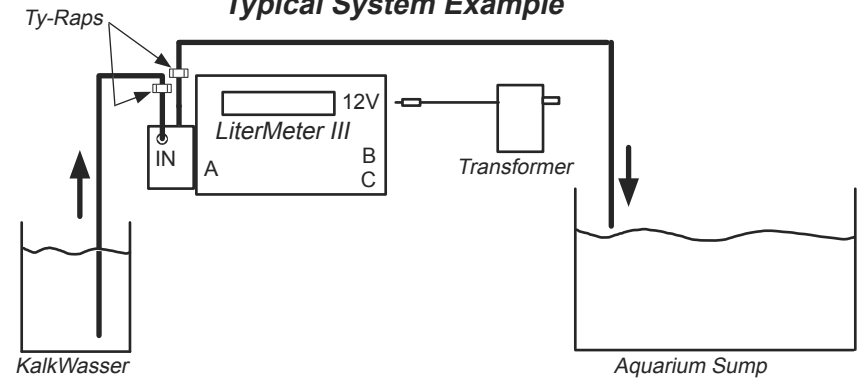

SYSTEM OPERATION

The LiterMeter III can control up to three dispensing devices in a sequential / cyclical manner. Only one device may be on at a time. The diagram below depicts maximum ON times for each device.

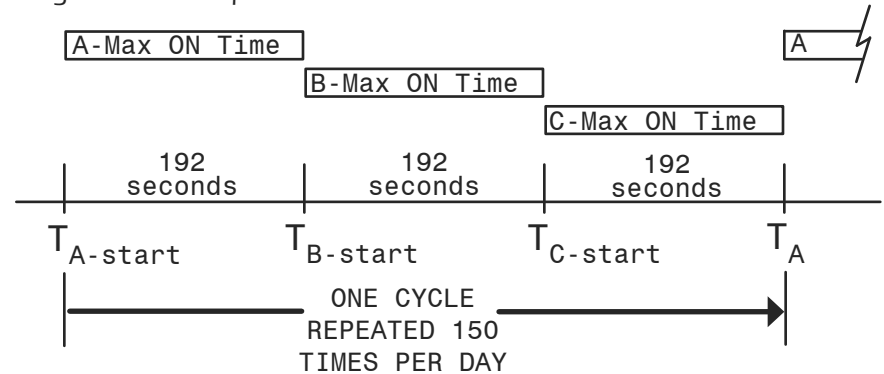

Every time the RUN/STOP switch is pressed, the operating MODE changes between RUN and STOP. In STOP mode, the pumps are disabled and the display will read *ALL PUMPS OFF*. When in STOP mode, the Calibrate and Maintenance functions are available. When in RUN mode, the pump(s) operate according to the current parameters. Note: if the requested daily total (FLOW) is less than approx. 150 ml/day, the pump may not immediately activate during the initial dosing cycle.

THE LIGHTS (LEDs)

The PoWeR LED indicates the wall-mounted power supply is functioning and the unit has power.

The SYSTEM LED normally blinks (in RUN mode) every other second, indicating that proper operation and time-keeping are proceeding.

Three PUMP LEDs indicate power is being applied to the pump motors. You may notice a very dim glow when a pump is off or not connected. This is a self-test function and not an error. If a pump LED is on, but the pump does not run, the pump head may be dirty and require servicing, or there may be a problem with the pump motor.

THE BUTTONS

When the LiterMeter III is in RUN mode, the group of four navigation buttons are used to change the RATE, FLOW and STATUS of the individual pumps. LEFT and RIGHT move the cursor across the display. UP and DOWN change the parameters (See pages 10-11).

When the unit is in STOP mode, the CALIBRate and MAINTenance functions are available. These functions display a series of questions that can be answered YES or NO.

THE INFORMATION DISPLAY

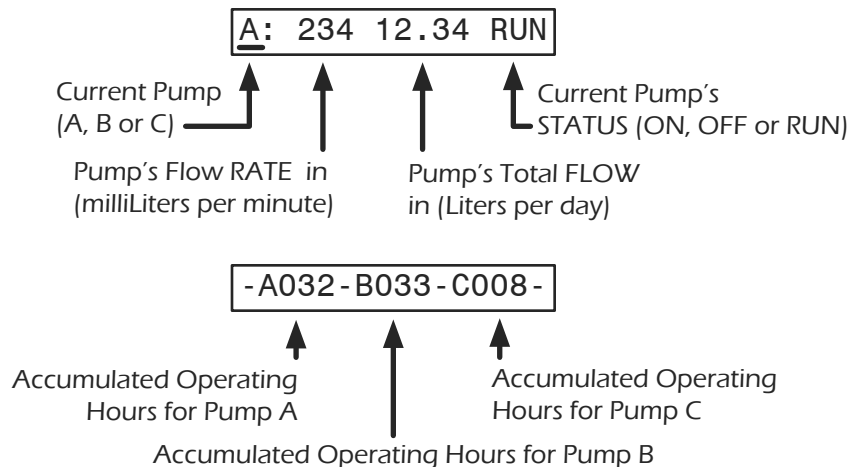

ACCESSORIES



LM3-MPM Micro Pump Module – Available 3rd quarter, 2003
Miniature Pump in plastic box. Connects to LiterMeter III for power and control.
4.0" x 2.0" x 1.7" (10.2 cm x 5.1 cm x 4.3 cm)



LM3-TCM Top-off Control Module – Plastic box with built-in Liquid Level Control (LLC). Connects to 12V input of LiterMeter III to interrupt power when high liquid level is reached.
3.0" x 2.0" x 1.7" (7.6 cm x 5.1 cm x 4.3 cm)

ACCESSORIES



LM3-RPM Remote Pump Module –
 LiterMeter III Pump mounted in plastic box. Connects
 to LiterMeter III for power and control.
 5.4" x 2.2" x 2.2" (13.7 cm x 5.6 cm x 5.6 cm)



LM3-WXM Water eXchange Module –
 LiterMeter III Pump mounted in plastic box with built-
 in Liquid Level Control (LLC). Interrupts power to
 pump when high liquid level is reached. Connects to
 LiterMeter III for power and control.
 5.4" x 2.2" x 2.2" (13.7 cm x 5.6 cm x 5.6 cm)

How to NAVIGATE across the Information Display

Move cursor LEFT and RIGHT
 across display to access and
 change parameters

How to View PUMP parameters

Step through three pump
 parameter displays and
 accumulated hours display

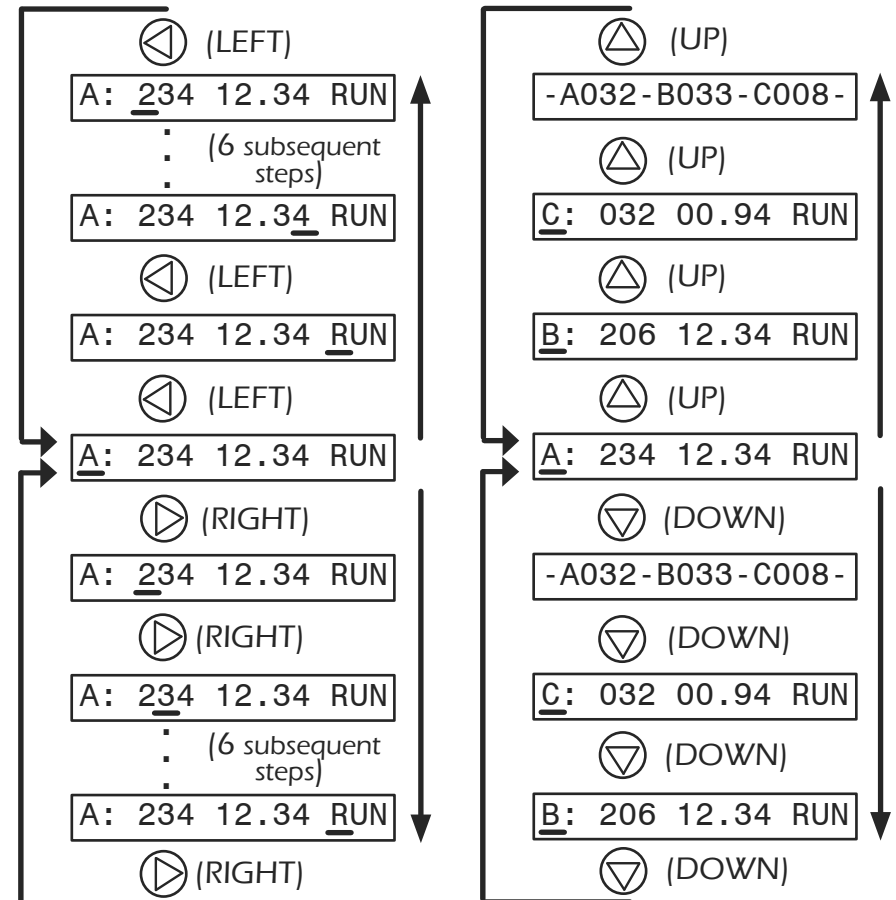

How to Change Any DIGIT in RATE or FLOW

Digits are stored as they are changed. Dosing schedule is re-calculated when STATUS is changed from OFF to RUN.

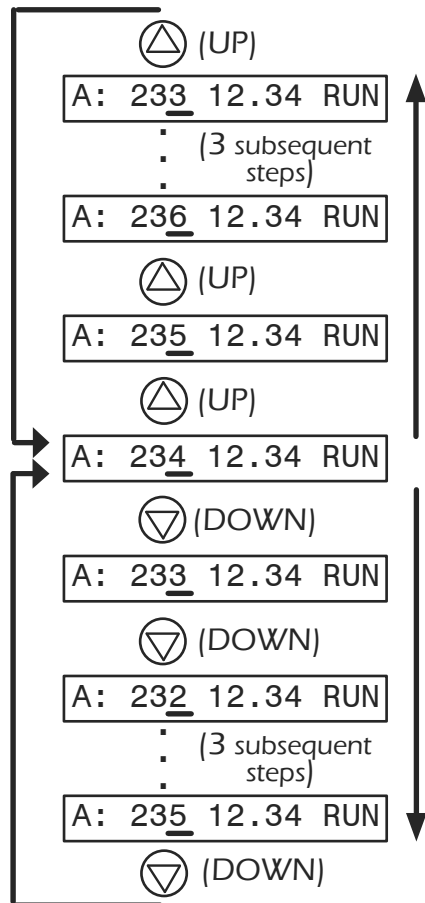

How to Change Pump Operation STATUS

OFF = Pump is always OFF
 ON = Pump is always ON
 RUN = Pump is dosing per parameter values

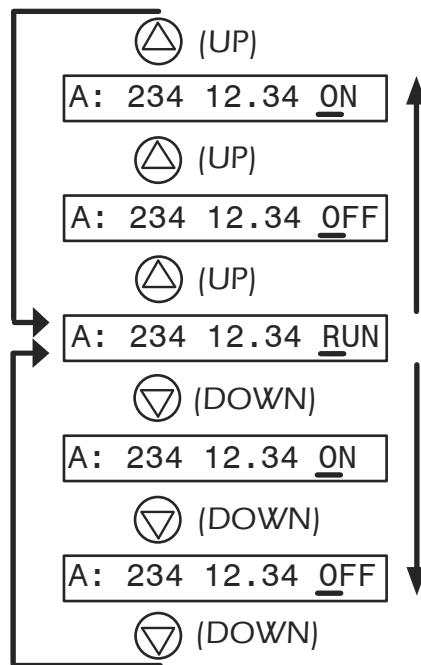

MAINTENANCE

Very little maintenance is required to keep your LiterMeter III operating reliably for many years. The LiterMeter III has a Service Interval Timer (500 hours) for each pump. When a pump's accumulated ON time exceeds the Service Interval Time Limit, the LiterMeter III will beep once per minute and flash a message on the display until the pump head is inspected and/or serviced and the Service Interval Timer is reset.

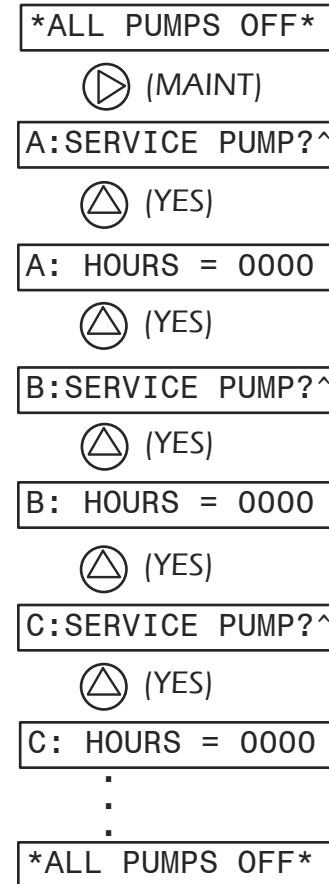

To reset the Service Interval Timer:

- 1: Be sure that **all pumps are off**.
- 2: Press the MAINT button (RIGHT) to display the pump that needs service. If, for example, Pump A has exceeded the Service Interval Time, the display will ask if you have serviced that pump. The pump head service procedure is described on page 17.
- 3: Answer YES by pressing the UP button.
- 4: The Service Interval Timer for Pump A will be reset to 0000 hours.
- 5: If other pumps need servicing, they will be displayed next.
- 6: If there are no other pumps that need service, the LiterMeter III will return to the *ALL PUMPS OFF* display.

As with any user-calibrated device, a periodic re-calibration should be performed to maintain original specifications.